

## Factory Fabricated Subsections

Each panel is shipped in factory assembled towers. Each tower assembly has top guides and bottom wheels factory installed. The towers bolt together in the field with a top and bottom splice channel and intermediate formed girts.

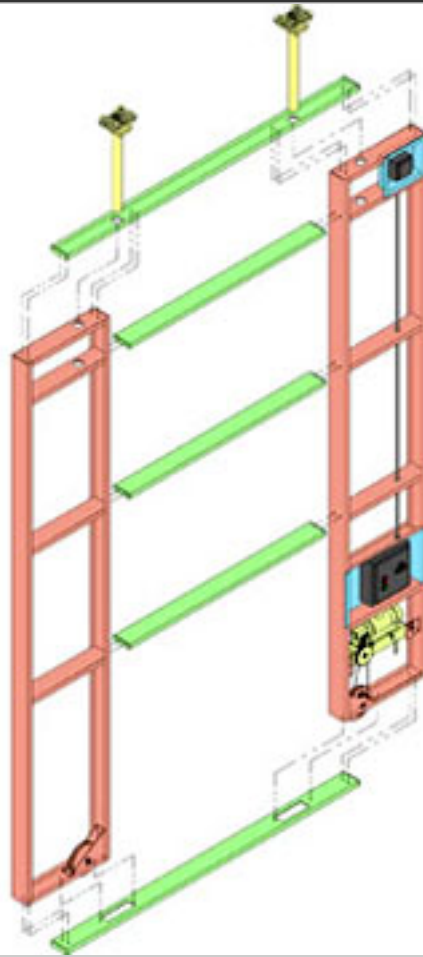

## Factory Installed and Wired Operator

The single lever disengage mechanism completely separates the motor drive assembly from the drive wheel for non-powered operation. A feature unique to the Door Engineering and Manufacturing Company operator. This system eliminates the possibility of any damage to the gear reducer and electric motor due to reversal of effort through the gear reducer and electric motor. It also does not require release of the electric motor shaft brake.

All wiring internal to the powered door section is completed and tested at the factory minimizing field wiring requirements.

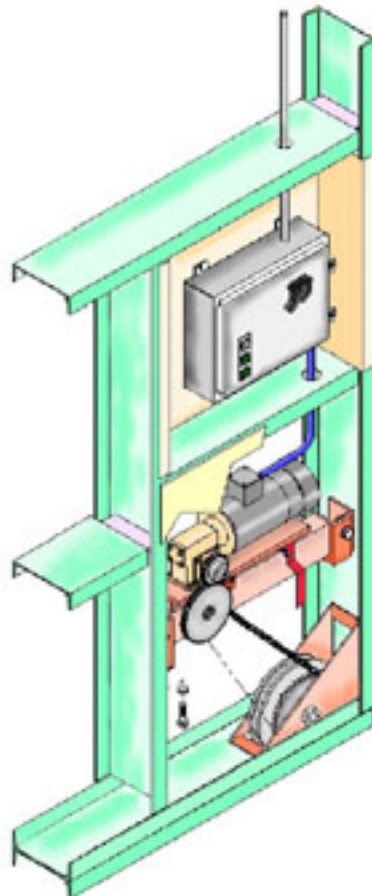

### Quick-set Guides and Rails

Top guides and bottom rails are shipped in factory fabricated sub-assemblies.

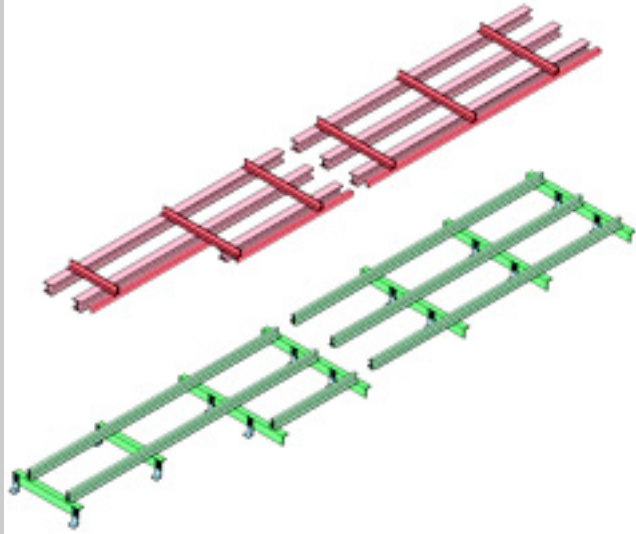

### Telescoping Top Rollers

True telescoping top roller assemblies can be fabricated to tolerate almost any amount to header deflection.

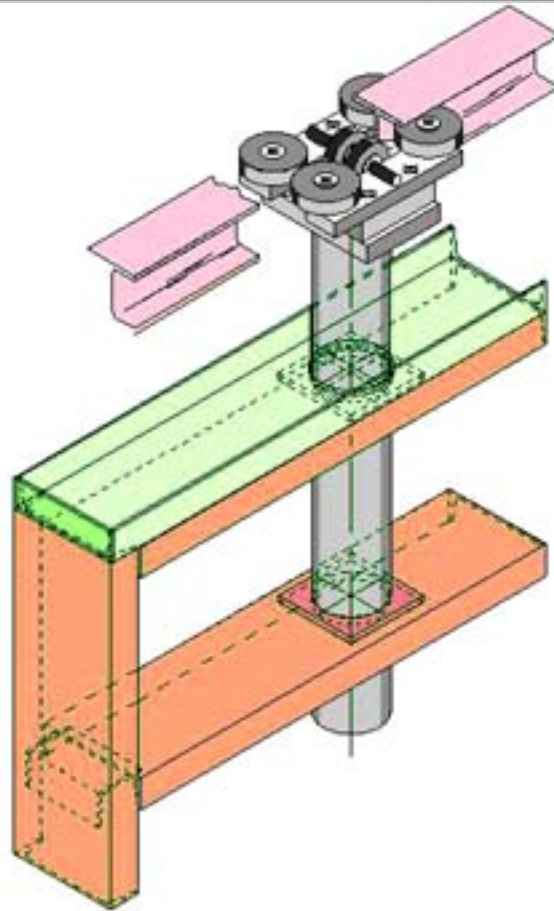

## Weatherseals

Factory installed dual opposing bulb vertical weather seals between door sections provide dramatically superior sealing in comparison to single or dual flap type weather seals.

